

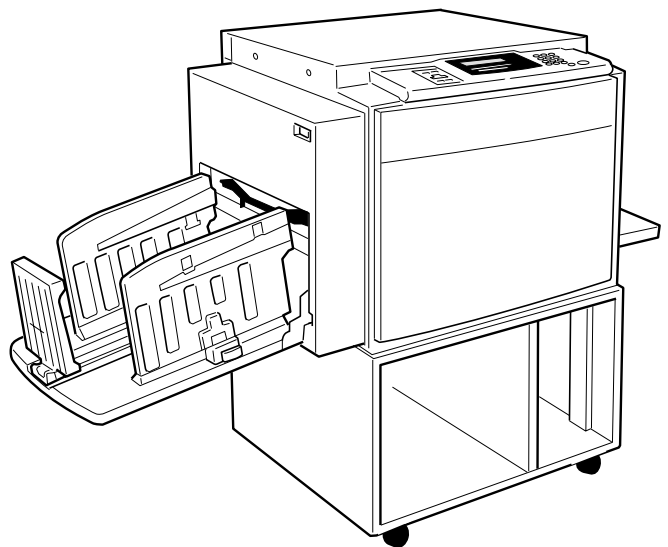

TC-II

Operating Instructions



Read this manual carefully before you use this product and keep it handy for future reference.

For safety, please follow the instructions in this manual.





TC-II Operating Instructions

Introduction

This manual contains detailed instructions on the operation and maintenance of this machine. To get maximum versatility from this machine all operators should carefully read and follow the instructions in this manual. Please keep this manual in a handy place near the machine.

Please read the Safety Information before using this machine. It contains important information related to USER SAFETY and PREVENTING EQUIPMENT PROBLEMS.



Notes:

Some illustrations might be slightly different from your machine.

Certain options might not be available in some countries. For details, please contact your local dealer.



Two kinds of size notation are employed in this manual. With this machine refer to the inch version.

Power Source

120V, 60Hz, 5.5 A or more

Please be sure to connect the power cord to a power source as above. For details about power source, ⇒ P.45 "*Power Connection*".

Note to users in the United States of America

Notice:

This equipment has been tested and found to comply with the limits for a Class B digital device, pursuant to Part 15 of the FCC Rules. These limits are designed to provide reasonable protection against harmful interference in a residential installation. This equipment generates, uses and can radiate radio frequency energy and, if not installed and used in accordance with the instructions, may cause harmful interference to radio communications. However, there is no guarantee that interference will not occur in a particular installation. If this equipment does cause harmful interference to radio or television reception, which can be determined by turning the equipment off and on, the user is encouraged to try to correct the interference by one more of the following measures:

Reorient or relocate the receiving antenna.

Increase the separation between the equipment and receiver.

Connect the equipment into an outlet on a circuit different from that to which the receiver is connected.

Consult the dealer or an experienced radio /TV technician for help.

Warning

Changes or modifications not expressly approved by the party responsible for compliance could void the user's authority to operate the equipment.

Note to users in Canada

Note:

This Class B digital apparatus complies with Canadian ICES-003.

Remarque concernant les utilisateurs au Canada

Avertissement:

Cet appareil numérique de la classe B est conforme à la norme NMB-003 du Canada.

In accordance with IEC 60417, this machine uses the following symbols for the main switch:

I means POWER ON.

O means POWER OFF.

Safety Information

When using your equipment, the following safety precautions should always be followed.

Safety During Operation

In this manual, the following important symbols are used:

⚠ WARNING:
Indicates a potentially hazardous situation which, if instructions are not followed, could result in death or serious injury.

⚠ CAUTION:
Indicates a potentially hazardous situation which, if instructions are not followed, may result in minor or moderate injury or damage to property.

⚠ WARNING:

- ***Connect the power cord directly into a wall outlet and never use an extension cord.***
- ***Disconnect the power plug (by pulling the plug, not the cable) if the power cable or plug becomes frayed or otherwise damaged.***
- ***To avoid hazardous electric shock, do not remove any covers or screws other than those specified in this manual.***
- ***To avoid injury, do not touch moving parts or insert your fingers in the opening during machine operation. To de-energize moving parts, open the front cover.***
- ***Turn off the power and disconnect the power plug (by pulling the plug, not the cable) if any of the following conditions exists:***
 - ***You spill something into the equipment.***
 - ***You suspect that your equipment needs service or repair.***
 - ***Your equipment's cover has been damaged.***

⚠ CAUTION:

- *Protect the equipment from dampness or wet weather, such as rain, snow, and so on.*
- *Unplug the power cord from the wall outlet before you move the equipment. While moving the equipment, you should take care that the power cord will not be damaged under the equipment.*
- *When you disconnect the power plug from the wall outlet, always pull the plug (not the cable).*
- *Do not allow paper clips, staples, or other small metallic objects to fall inside the equipment.*
- *For environmental reasons, do not dispose of the equipment or expended supply waste at household waste collection points. Disposal can take place at an authorized dealer or at appropriate collection sites.*
- *Be careful not to cut yourself on any sharp edges when you reach inside the machine to remove misfed sheets of paper or masters.*
- *Our products are engineered to meet high standards of quality and functionality, and we recommend that you only use the expendable supplies available at an authorized dealer.*

How to Read This Manual

Symbols

In this manual, the following symbols are used:

 **WARNING:**

This symbol indicates a potentially hazardous situation that might result in death or serious injury when you misuse the machine without following the instructions under this symbol. Be sure to read the instructions, all of which are described in the Safety Information section.

 **CAUTION:**

This symbol indicates a potentially hazardous situation that might result in minor or moderate injury or property damage that does not involve personal injury when you misuse the machine without following the instructions under this symbol. Be sure to read the instructions, all of which are described in the Safety Information section.

* The statements above are notes for your safety.

 **Important**

If this instruction is not followed, paper might be misfed, originals might be damaged, or data might be lost. Be sure to read this.

 **Preparation**

This symbol indicates the prior knowledge or preparations required before operating the machine.

 **Note**

This symbol indicates precautions for operation, or actions to take after misoperation.

 **Limitation**

This symbol indicates numerical limits, functions that cannot be used together, or conditions in which a particular function cannot be used.

 **Reference**

This symbol indicates a reference.

[]

Keys that appear on the machine's display panel.

[]

Keys built into the machine's operation panel.

What You Can Do with This Machine

Below is a quick summary of this machine's features and where to look in this manual for more information.

❖ Standard Printing

⇒ P.15 “Standard Printing”.

❖ Adjusting the Print Image Position

⇒ P.20 “Adjusting the Position of Printed Images”.

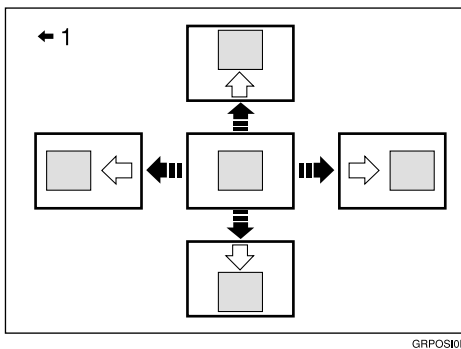

1: Paper feed direction

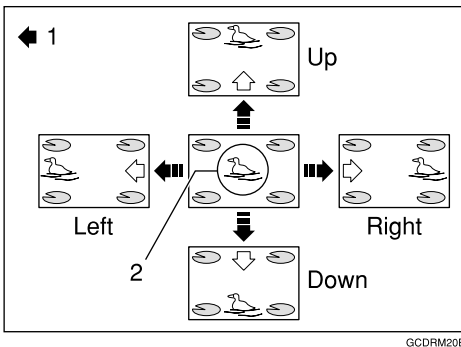

1: Paper feed direction

2: Image of Drum 2

❖ Changing the Printing Speed

⇒ P.22 “Changing the Printing Speed”.

TABLE OF CONTENTS

Machine Exterior	1
Machine Interior	2
Operation Panel	4
Keys	4
Indicators.....	5

1. Operation

Setting and Changing the Drum Unit	7
Setting the Drum Unit.....	7
Changing the Drum Unit.....	9
Printing Preparations	10
Loading Paper.....	10
Setting Up the Paper Delivery Table.....	11
Turning on the Main Power	12
Print Paper	13
Standard Printing	15
Removing Prints.....	16
Printing onto Various Kinds of Paper	17
Printing onto Thick Paper.....	17
Printing onto Standard Paper.....	17
Printing onto Special Kinds of Paper.....	17
Paper Supply Adjustment.....	18
Adjusting the Position of Printed Images	20
Changing the Printing Speed	22
Skip Feed Printing	23

2. User Tools

Accessing the User Tools	25
User Tools	26
1. System	26

3. Troubleshooting

If Your Machine Does Not Operate as You Want.....	29
If You Cannot Make Prints as You Want	30
Loading Paper.....	31
When the Add Ink Indicator (🖨️) Lights.....	32
🔧 Clearing Misfeeds.....	34
Paper Misfeed in the Paper Feed Section	34
Paper Misfeed in the Paper Feed Section	35
Paper Wrapped around the Drum	36
Paper Misfeed in the Paper Exit Section.....	38
Poor Printing.....	39
Dirty Background.....	39
When the Press Roller is Dirty	41
Faint Prints	41

4. Remarks

Do's and Don'ts	43
Where to Put Your Machine.....	44
Environment.....	44
Power Connection.....	45
Machine Clearance	45
Maintaining Your Machine.....	46
Cleaning the Main Frame.....	46

5. Specifications

Main Frame.....	47
Consumables.....	49
INDEX.....	50

Machine Exterior

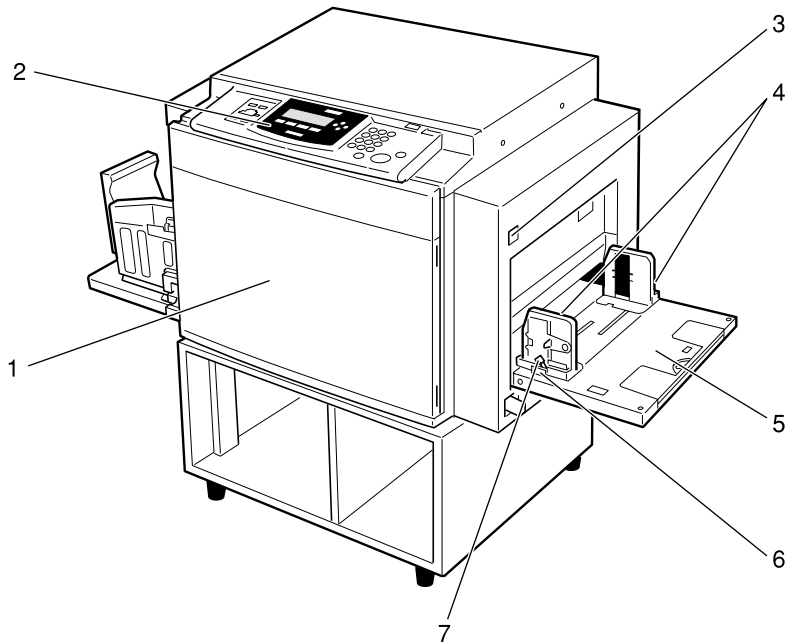

ZBRH010E

1. Front door

Open to access the inside of the machine.

2. Operation panel

⇒ P.4 "Operation Panel".

3. Paper feed tray down key

Press to lower the Paper feed tray.

4. Paper feed side plates

Prevent paper being fed skewed.

5. Paper feed tray

Set paper here.

6. Paper feed side plates knob

Use to move the side plates.

7. Paper feed side plates knob lock lever

Fix to the paper feed side plates knob.

Machine Interior

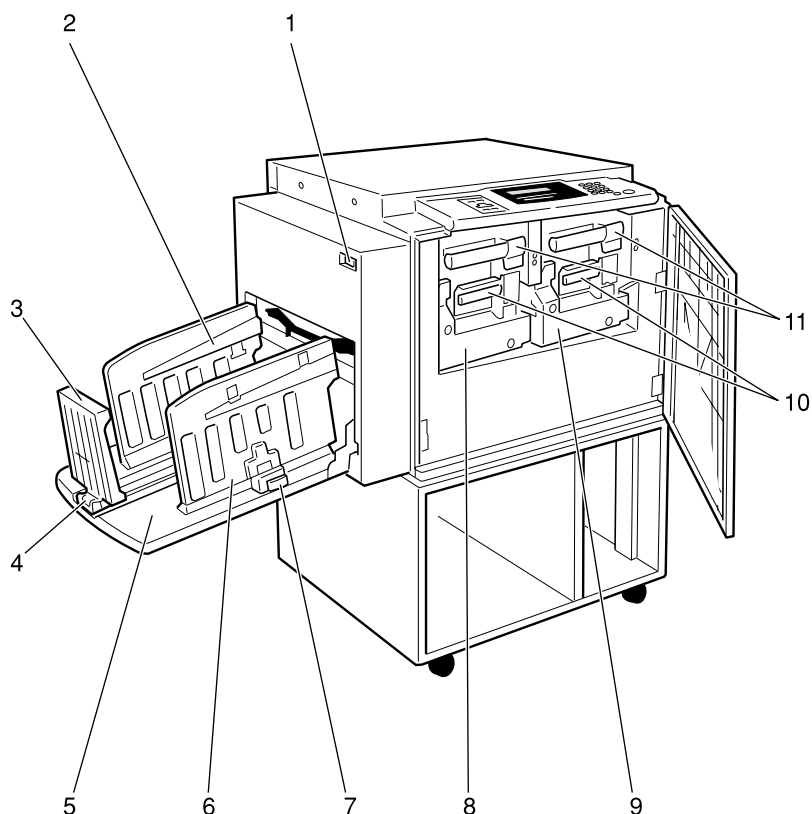

ZBRH020E

1. Main switch

Use to turn the power on or off.

2. Paper alignment wings

Lift or lower the wings depending on the type of paper being used.

3. Paper delivery end plate

This plate aligns the leading edge of prints.

4. Paper delivery end plate knob

Use to move the end plate.

5. Paper delivery tray

Completed prints are delivered here.

6. Paper delivery side plates

These plates align the prints on the paper delivery tray.

7. Paper delivery side plate knobs

Use to move the side plates.

8. Drum Unit 2

The master is wrapped around this unit.

9. Drum Unit 1

The master is wrapped around this unit.

10. Ink holder

Set the ink cartridge in this holder.

11. Drum unit lock lever B1

Lower to unlock and pull out the drum unit.

12. Trailing edge guides

Swing out these guides when you use B5 paper.

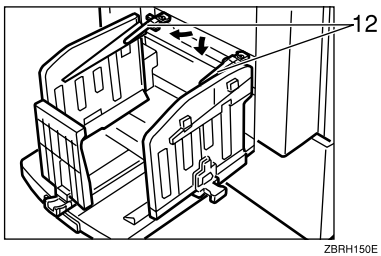

Operation Panel

Keys

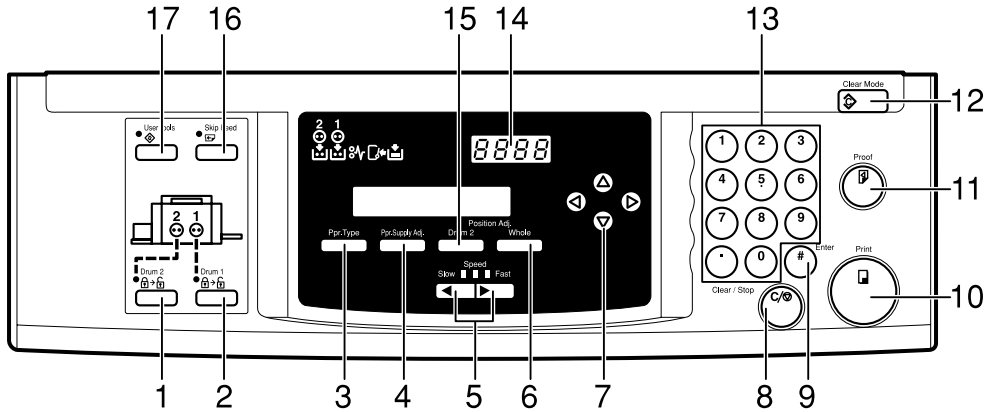

ZBRS011N

1. **[Drum2]** key

Press when you need to set or change the Drum 2 ⇒ P.7 "Setting the Drum Unit".

2. **[Drum1]** key

Press when you need to set or change the Drum 1 ⇒ P.7 "Setting the Drum Unit".

3. **[Ppr.Type]** key

Press to select the paper type ⇒ P.17 "Printing onto Various Kinds of Paper".

4. **[Ppr. Supply Adj]** key

Press to change the paper feeding ratio and paper separation ratio. ⇒ P.18 "Paper Supply Adjustment".

5. **[◀][▶]** keys (Speed keys)

Press to adjust the printing speed. ⇒ P.4 "Keys", ⇒ P.22 "Changing the Printing Speed".

6. **[Position Adj/Whole]** key

Press to adjust the mixed image positions of Drum1 and Drum2 ⇒ P.20 "Adjusting the Position of Printed Images"

7. **[◀][▶][▲][▼]** keys

Press to shift the image forward, backward, right, or left. ⇒ P.4 "Keys", ⇒ P.20 "Adjusting the Position of Printed Images".

Also use to highlight items you wish to select on the panel display.

8. **[Clear/Stop]** key

Press to stop printing.

9. **[#]** key

Use to enter data in selected modes.

10. **[Print]** key

Press to start printing.

11. **[Proof]** key

Press to make proof prints.

12. **[Clear Modes]** key

Press to clear any previously entered job settings.

13. **Number keys**

Press to enter the desired number of prints and data for selected modes.

14. **Counter**

Displays the number of prints entered. While printing, it shows the number of prints remaining.

15. **[Position Adj/Drum2]** key

Press to adjust the image position's of Drum2.

16. **[Skip Feed]** key

Press to select skip feed printing. ⇒ P.23 "Skip Feed Printing"

17. **[User Tools]** key

Press to change the default settings to meet your requirement.

Indicators

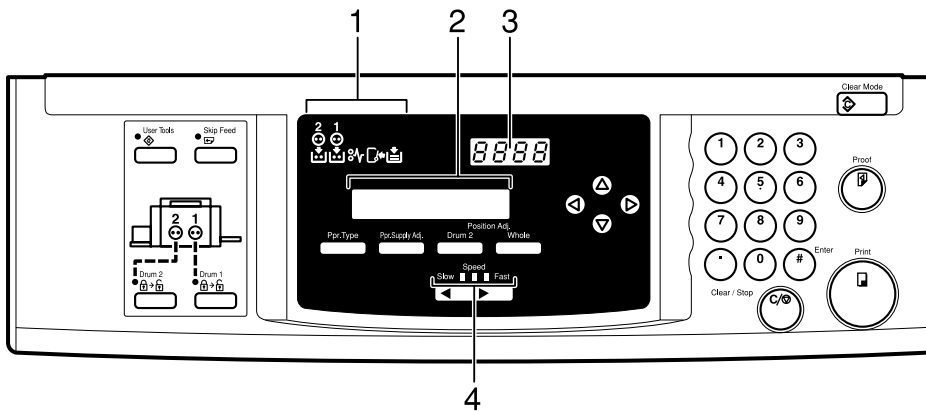

ZBRS012N

1. Error Indicators

These indicators are lit when a non-standard condition occurs within the machine.

2. Guidance Display

Display the machine's condition.

3. Counter

Displays the number of prints entered. While printing, it shows the number of prints remaining.

4. Speed Indicators

These indicators show the printing speed that is selected.

5. Drum set indicator

The green indicator lights when the drum unit is ready to pull out. If not ready, the red indicator lights.

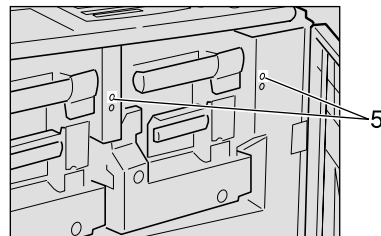

ZBRH040E

1. Operation

Setting and Changing the Drum Unit

Before you start printing, you must make a master print using the master making unit. The master print is wrapped around the drum unit.

Note

- Color drum units are available as options in addition to the standard black unit. For making color prints, a separate drum unit is necessary for each color.
- Insert the same kinds of drum unit for both Drum 1 and Drum 2.
- Color Drum Type 50S/80S is not available for this machine.
- A4 size master cut drum is not available for this machine.

Setting the Drum Unit

- 1** Make sure that you select either **[Drum1]** or **[Drum2]** before setting the drum unit.

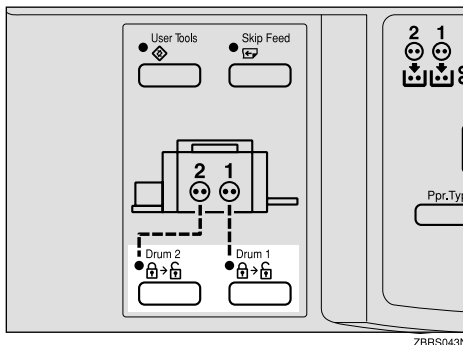

Note

- Make sure that the indicator is lit.

- 2** Open the Front Door.

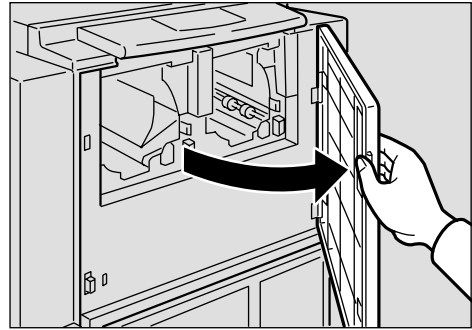

- 3** Lift upper drum stay B3 a little to unlock the drum unit, then push into the drum unit while holding drum unit handle B2 and upper drum stay B3.

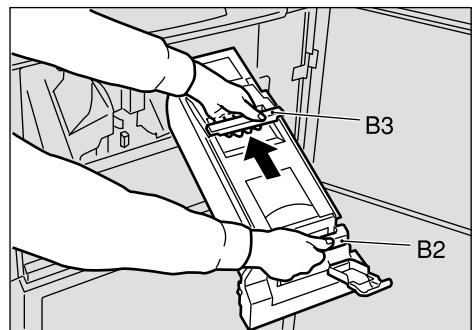

Note

- Make sure the green light beside the drum unit lock lever is on.
- If the red light is on, go back to step 1.

- Make sure that the drum unit lock lever B1 is released.

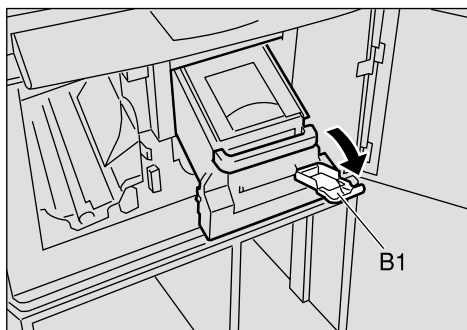

ZBRH120E

- 6** Lift drum unit lock lever B1.

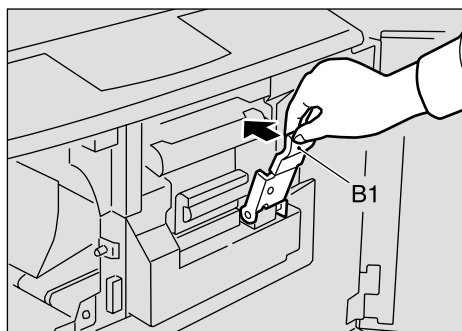

ZBRH031E

- 4** Insert the drum unit along the guide rail.

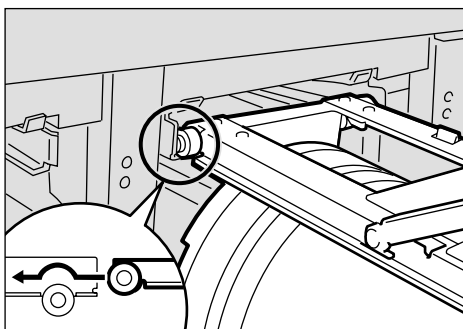

ZBRH160E

- 7** Close the front door.

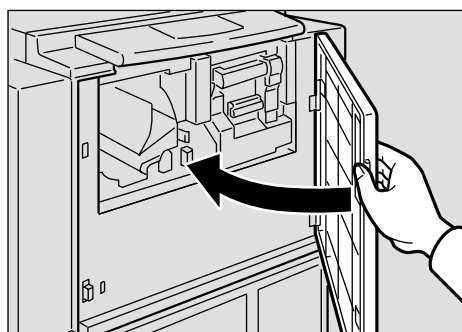

ZBRH110E

- 5** Slide in the drum unit until it locks in position.

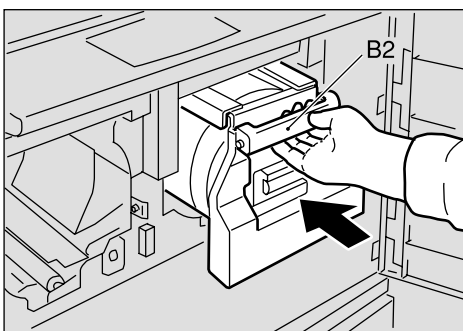

ZBRH051E

Note

- If you want to set another drum unit, go back to step 1.
- Make sure that the Open Cover Indicator turns off.

Note

- Insert the same kinds of drum unit for both Drum1 and Drum2.

Changing the Drum Unit

- 1** Make sure that you select either **[Drum1]** or **[Drum2]** before changing the drum unit.
- 2** Open the front door.
- 3** Make sure the green light beside the drum unit lock lever is on before sliding out the drum. If the red light is on, go back to step **1**.

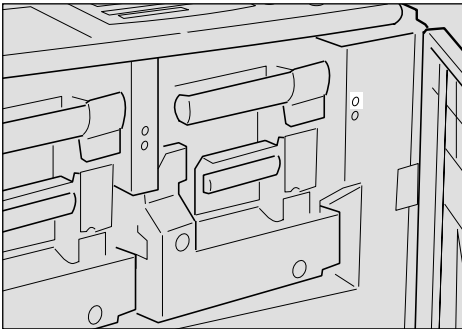

- 4** Lower the drum unit lock lever B1.

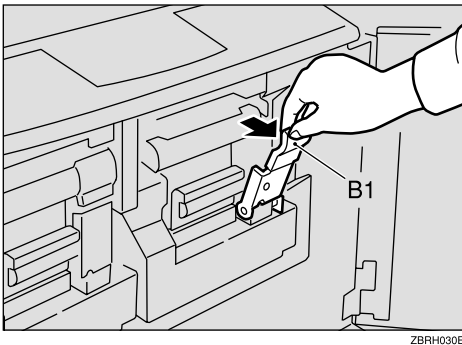

- 5** Pull out drum unit handle B2 slowly.

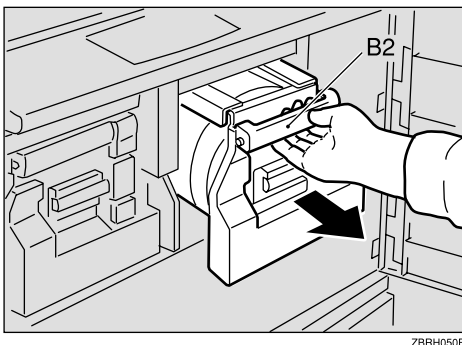

- 6** Lift upper drum stay B3 a little to unlock the drum unit, then pull out the drum unit while holding drum unit handle B2 and upper drum stay B3.

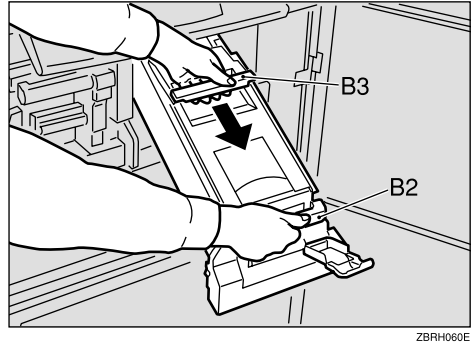

⚠ Important

- Be careful not to let the drum unit fall.

- 7** Insert the color drum unit along the guide rail.
- 8** Lower drum unit lock lever B1 of the inserted drum.
- 9** Slide in the drum unit until it locks in position.
- 10** Lift drum unit lock lever B1.
- 11** Close the front door.

📌 Note

- Make sure that the Open Cover indicator turns off.

Printing Preparations

1

Loading Paper

1 Carefully open the paper feed tray.

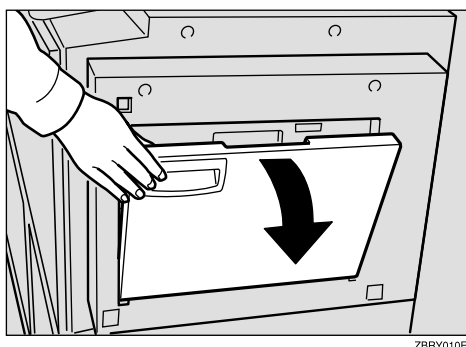

ZBRY010E

2 Lift the feed side/end plates.

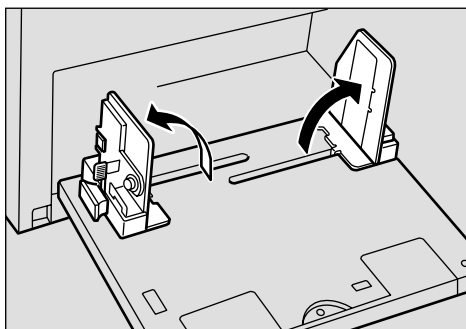

ZBRY030E

3 Make sure that the lock lever for the side plate is raised (lock is released), and then grasp the side plate knob and adjust the side plate to match the paper size.

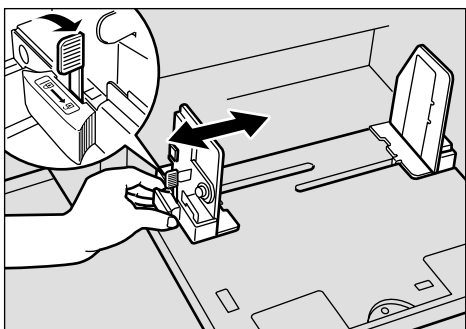

ZBRY040E

Important

Always adjust the position with the lock lever for the paper feed side plates in the raised position (lock released).

4 Place the paper on the paper feed tray.

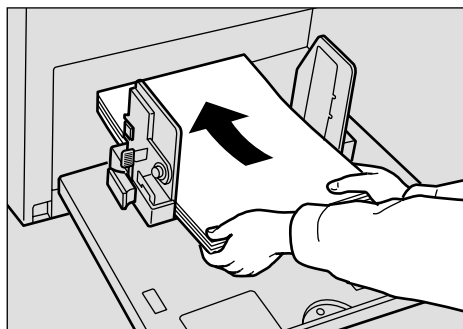

ZBRY050E

Note

Correct the paper curl before loading the paper. If you cannot do so, stack the paper with the curl face down.

Reference

⇒ P.13 "Print Paper"

5 Make sure that the paper feed side plates are touching both sides of the paper, and then push the lock lever for the side plates down to lock the side plates into position.

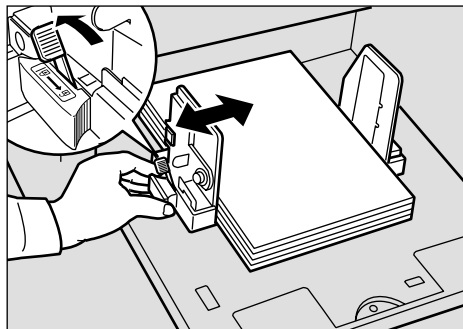

ZBRY060E

Important

- Always make sure that you push the lock lever for the side plates down to lock the side plates in position.

Note

- Make sure that the paper size and direction in the panel display correspond with the actual paper size and direction set on the paper feed tray.

- 3** Adjust the paper delivery end plate to match the print paper size.

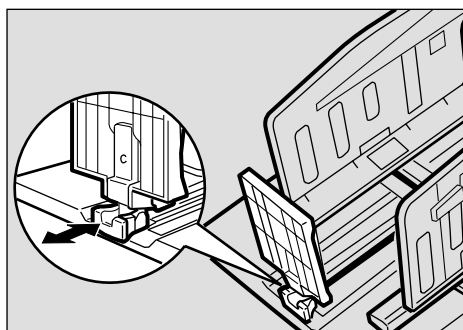

ZBH070E

Note

- The inside of the end plate should align with the paper size scale.

Setting Up the Paper Delivery Table

- 1** Open the Paper Delivery Table.

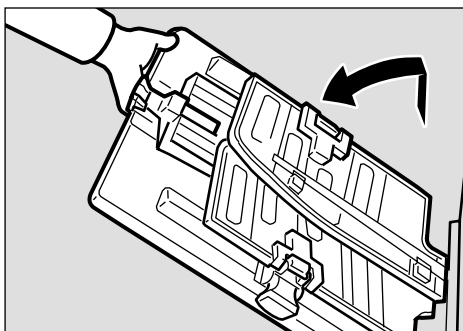

ZBRH181E

- 2** Lift the paper delivery plates and adjust the side plates to the paper size.

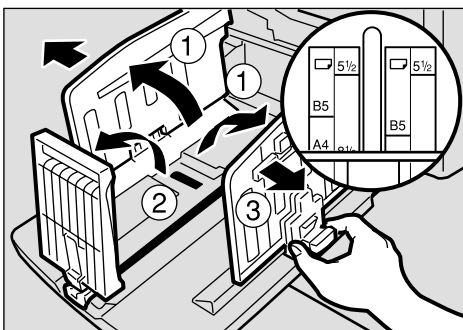

ZBRY080E

Note

- The inside of the side plates should align with the paper size scale.

- 1** Adjust the side plates to match the paper size scale on the main frame side.

When you use standard paper (52.3 g/m² to 81.4 g/m², 13.9 lb to 21.6 lb)

- 1** Adjust the side plates to match the paper size scale on the end plate side.

When you use thick paper (81.4 g/m² to 209.3 g/m², 21.6 lb to 55.6 lb)

- 4** Lower or lift the paper alignment wings.

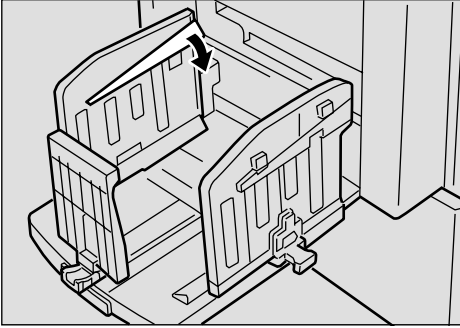

Note

- When the guides are up, you might not be able to load the unit to full capacity (1,000 sheets) depending on the paper you are using.
- Lift the paper alignment wings when B5 paper prints are curled.

When you use 81.4 g/m², 21.6 lb or thicker paper

- 1** Lower the paper alignment wings.

When you use B5 paper

- 1** Swing out the trailing edge guides.

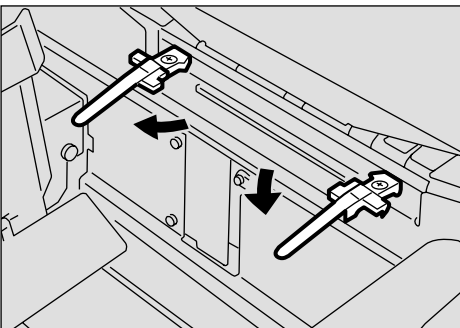

Turning on the Main Power

- 1** Make sure that the power cord is firmly plugged into the wall outlet.
- 2** Turn on the main power switch.

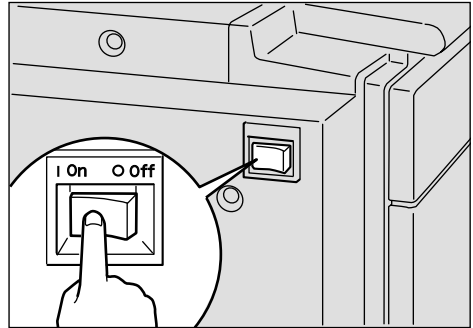

Print Paper

The following limitations apply:

	Paper Size		Paper Weight
	Metric	Inch	
Paper feed tray	A3 ☐, B4 ☐, A4 ☐, B5 ☐, Others (Vertical: 70 - 297mm, Horizontal: 250 - 432mm)	11" × 17" ☐, 8½" × 14" ☐, 8½" × 11" ☐, Others (Ver- tical: 2.76" - 11.7", Horizon- tal: 9.84" - 17")	52.3 - 209.3g/m ² , 13.9 - 55.6 lb

Non-recommended paper and envelope:

- Roughly cut paper/envelope
- Paper of different thickness in the same stack
- Envelopes heavier than 85g/m², 22 lb.
- Folded, curled, creased, or damaged paper
- Torn paper
- Slippery paper
- Rough paper/envelope
- Paper with any kind of coating (such as carbon)
- Short grain paper
- Thin paper that has low stiffness
- Paper that is prone to generate a lot of paper dust
- Grained paper loaded with the direction of the grain perpendicular to the feed direction
- Certain types of long thin envelopes e.g. international mail envelopes
- The following types of envelopes:

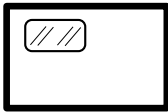
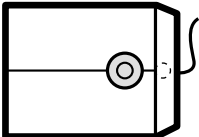
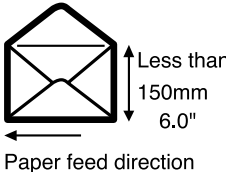
Envelopes with glue or gum	Envelopes with windows	Envelopes with round tags	Open envelopes
			

Note

- ☐ If you print on rough grained paper, the following problems may occur:
 - Black-Spotted image
 - Blurred image
 - Damaging master

Important

- ❑ Correct curls in the paper before placing it in the machine. When you cannot correct the paper curl, stack the paper with the curl face down or face up as shown in the illustration. If paper is curled, it might wrap around the drum or stains might appear.

1

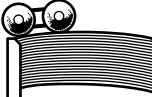
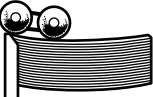
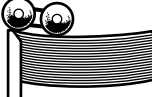
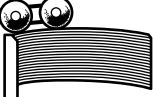
	Right	Wrong
Thin Paper		
Thick Paper		

TPEY990E

Standard Printing

1 Set the Drum Unit.

Reference

⇒ P.7 “Setting the Drum Unit”

2 Make sure that the machine is ready for printing.

3 Make sure that there are no previous settings remaining.

Note

- To clear any previous settings, press the **[Clear Modes]**.

4 Set the paper

Reference

⇒ P.10 “Loading Paper”

5 Select the Paper type

Reference

⇒ P.17 “Printing onto Various Kinds of Paper”

6 Set your desired settings.

7 Press the **[Proof]** Key.

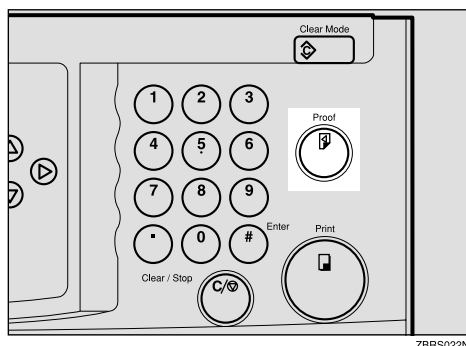

Note

- If the Image position is not correct, adjust it by using **[Whole]** or **[Drum 2]**. ⇒ P.20 “Adjusting the Position of Printed Images”.

- If the image density is slightly dark or light, adjust the image density, using **[◀]** **[▶]** Speed keys. ⇒ P.22 “Changing the Printing Speed”.

8 Enter the number of prints required with the number keys.

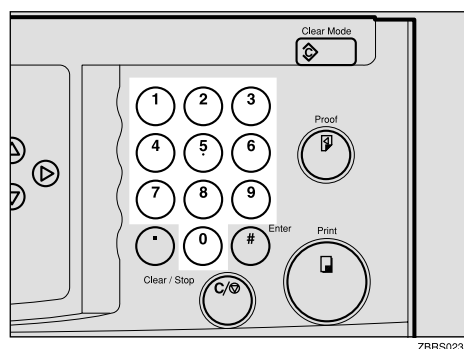

Note

- The counter shows the number of prints you set.



- To change the number entered, press the **[Clear/Stop]** key and enter the new number.

9 Press the **[Print]** key.

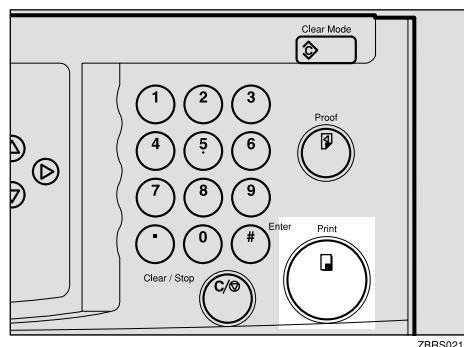

Note

- To stop the machine during a multi-print run, press the **[Clear/Stop]** key.
- To return the machine to the initial condition after printing, press the **[Clear Modes]** key.

Removing Prints

- 1** Pull the front paper delivery side plate down towards you to open it.

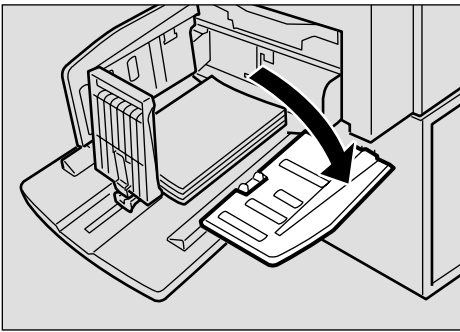

ZBRY110E

- 2** Remove the prints from the paper delivery tray and close the paper delivery side plate.

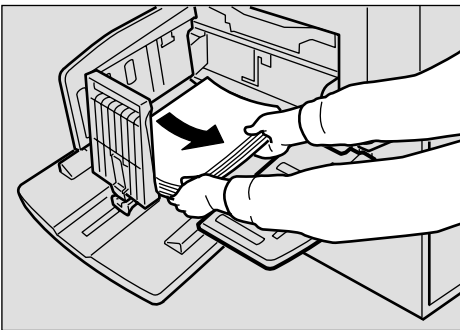

ZBRY120E

Auto Reset

The machine returns to its initial condition automatically after your job is finished.

This function is called "Auto Reset".

Note

- You can change the time the machine can wait before Auto Reset mode starts.⇒ P.26 "User Tools".
- The machine will not automatically enter Auto Reset mode in the following cases:
 - If there is no ink
 - If paper misfeed occur
 - If the machine is printing
 - If there is no paper
 - If the cover open message is displayed

Auto Off

If you do not operate the machine for a certain period the machine can enter Quality Standby mode to remove ink from inside the machine, and then turn itself off. This function is called "Auto Off".

Limitation

Quality Standby mode does not available when you use Color Drum Type 40S/50S.

Note

- You can change the time the machine can wait before Auto Off mode starts.⇒ P.26 "User Tools".

Printing onto Various Kinds of Paper

Before printing onto thick paper, thin paper, envelopes or special kinds of paper loaded in the Paper feed tray, you must select the paper type.

Printing onto Thick Paper

If you wish to print onto thick (157 to 209.3g/m², 42 to 55.6 lb or heavier) paper, perform the following steps.

- 1 Press the [Ppr.Type] key.

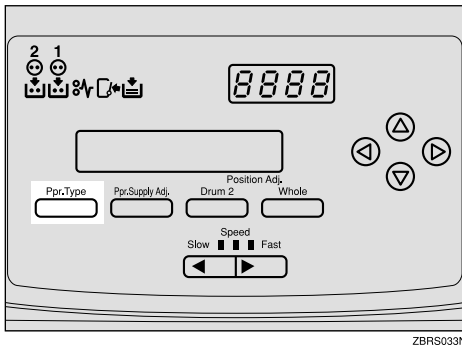

- 2 Select [2:THICK] with [◀][▶] key.

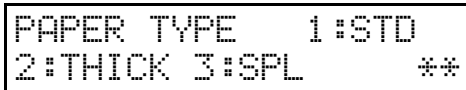

- 3 Press the [#] key.

Printing onto Standard Paper

- 1 Press the [Ppr.Type] key.

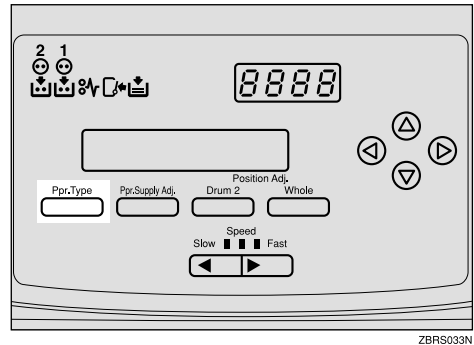

- 2 Make sure that [1:STD] is selected.

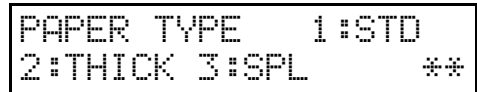

- 3 Press the [#] key.

Printing onto Special Kinds of Paper

- 1 Press the [Ppr.Type] key.

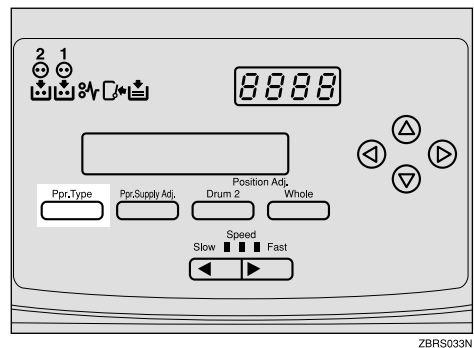

- 2 Select [3:SPL] with [◀][▶] key.

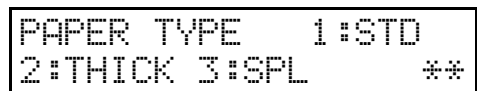

3 Press the [#] key.

Printing onto envelopes

1 Place the envelopes in the paper feed tray as shown in the illustration.

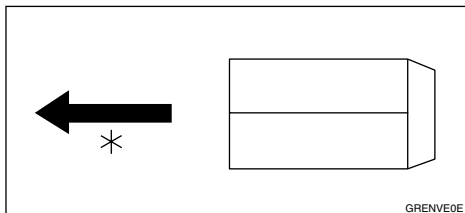

*: Paper feed direction

Note

- When you use envelopes, the Paper feed tray capacity is about 150 sheets (85g/m², 22 lb) or enough to load a stack up to 105mm, 4.1" high.
- 2** If your envelopes do not feed in well, lift the paper feed tray a little, and then lower it so that it slants up slightly.

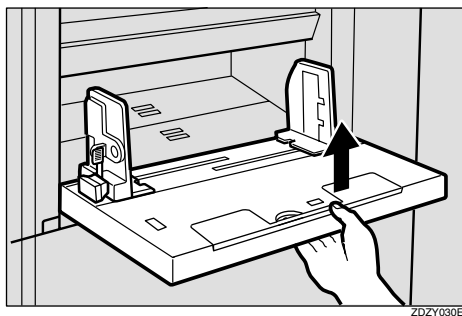

Paper Supply Adjustment

If paper misfeeds occur frequently, you can adjust the paper feeding ratio and paper separation ratio.

1 Press the [Ppr. Supply Adj] key.

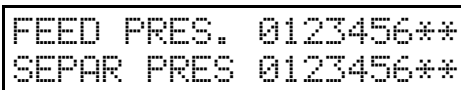
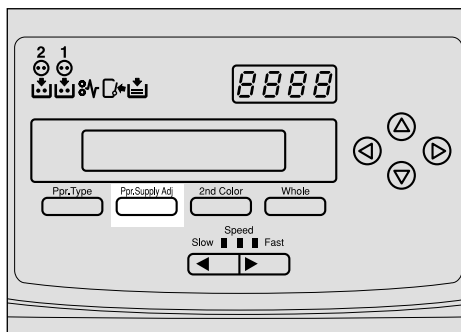

2 Press [◀] [▶] [▲] [▼] or the number keys to adjust the paper feeding ratios and the paper separation ratios.

3 Press [#] key.

If the machine does not feed enough paper

1 Change the paper feeding ratio setting as follows.

Paper type	Paper feed pressure ratio
Standard	5-6(*3)
Thick	6(*5)
Special kinds of Paper	5-6(*3)

*: Default

If the machine feeds too much paper

- ① Change the paper separation ratio setting as follows.

Paper type	Paper feed separation ratio
Standard	4~6(*3)
Thick	3~4(*2)
Special kinds of Paper	3~4(*1)

*: Default

Adjusting the Position of Printed Images

Use the following procedure to adjust the position of print images as required.

Note

Unexpected change to the image position may occur with the following actions:

- Switching Drum1 and 2.
- Remaking a master using the master making unit.
- Changing the print speed.

There are two kinds of image adjustment as follows:

Overall Image Adjustment

You can adjust the mixed image position of Drum1 and Drum2.

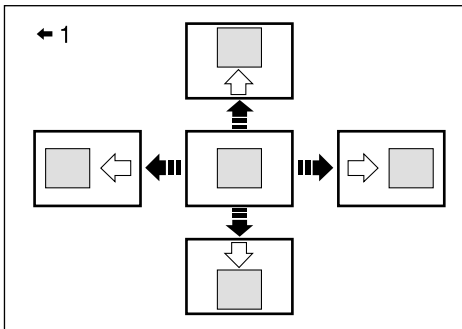

1: Paper feed direction

Drum2 Image Adjustment

You can adjust the image position of Drum2.

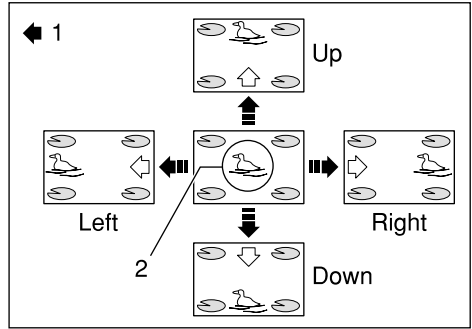

1: Paper Feed Direction
2: Image of Drum2

Note

When the main switch is turned off, the image returns to the default position.

1 Press the [Whole] or [Drum 2] key.



2 Adjust the image position using the [◀], [▶], [▲], and [▼] keys.

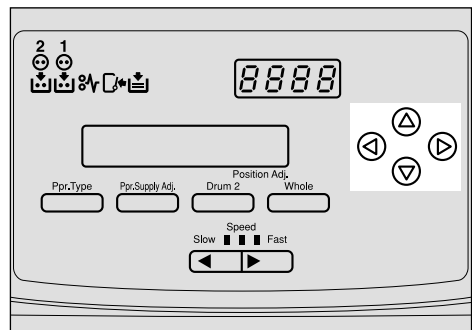

Note

- ❑ When you shift the image forward, leave a 10mm, 0.4" margin at the leading edge. If there is no margin, paper might wrap around the drum and cause a misfeed.
- ❑ If you adjust the image position, a print shadow might appear.

Overall image adjustment

- 1 You can change the overall image position of both Drum 1 and 2. Use [◀] [▶] [▲] [▼] keys to shift the image each way in 0.5mm, 0.02" steps.

Up & Down	Right & Left
+10mm, 0.4" or -10mm, 0.4"	+10mm, 0.4" or -10mm, 0.4"

Drum 2 image adjustment

- 1 You can change the image position of Drum 2. Use [◀] [▶] [▲] [▼] keys to shift the image each way in 0.25mm, 0.01" steps.

Up & Down	Right & Left
Moving sums of both adjustment functions (Max 10mm, 0.4")	+5mm, 0.2" or -5mm, 0.2"

- 3 Press the [Enter] key.

- 4 Press the [Proof] key to check the image position.

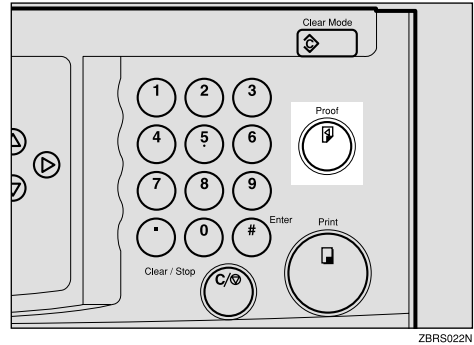

Changing the Printing Speed

1

Use the [◀] or [▶] key to adjust the printing speed. The relationship between printing speed and print quality depends on the type of paper you use.

1 Press the [▶] key to increase the speed and press the [◀] key to reduce the speed.

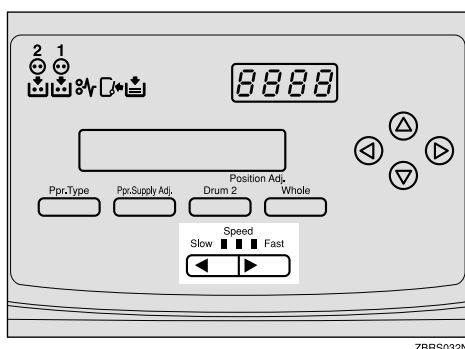

ZBRS032N

Note

- The following speeds are available:
 - Setting 1 (default):
90 sheets/minute
 - Setting 2:
105 sheets/minute
 - Setting 3:
120 sheets/minute
- The faster the printing speed becomes, the lighter the printing density is, and vice versa.
- If you change the print speed while printing, a print shadow might appear.
- When the machine is used in low temperature conditions, the image density might decrease. In this case, use setting one.

Skip Feed Printing

If the backs of prints are dirty, you can increase the time between prints using the **[Skip Feed]** key. By default, when one sheet of paper is fed the drum rotates once. However, you can select the number of rotations of the drum. This gives you the chance to remove prints one by one from the paper delivery tray or insert one sheet of paper between two prints. If you use this function, you can also use paper longer than 432mm, 17.0" in spite of the maximum length limitations of paper.

Note

- ❑ Two rotations per sheet of paper is the default. You can change this default setting with the user tools. See "No. of Skip Feed" ⇒ P.23 "Skip Feed Printing".
- ❑ The maximum length of paper in Skip Feed mode is 460mm, 18.1".
- ❑ When you use paper longer than 432mm, 17.0", completed prints will not be delivered to the paper delivery tray properly, so lower the paper delivery end plate and receive completed prints by hand.

1 Press the **[Skip Feed]** key.

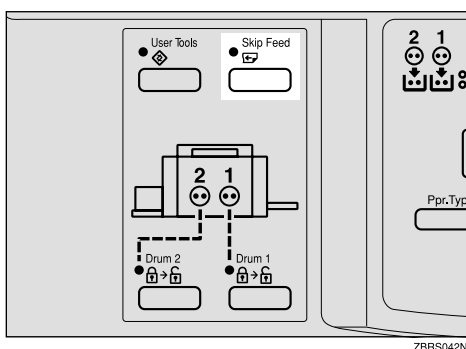

2 If necessary, select the number of rotations of the drum per sheet of paper fed with the **[<] [>]** keys.

```
SKIP FEED NO SETTING
INPUT THE NUMBER *
```

Note

- ❑ You can also select the number of rotations with the Number keys.
- ❑ You can select from 2 to 9 rotations.
- ❑ By default, the machine asks you to confirm the number of rotations. You can have this step omitted by adjusting the user tool settings. See "No. of Skip Feed" ⇒ P.26 "User Tools".

3 Press the **[#]** key.

4 Press the **[Start]** key.

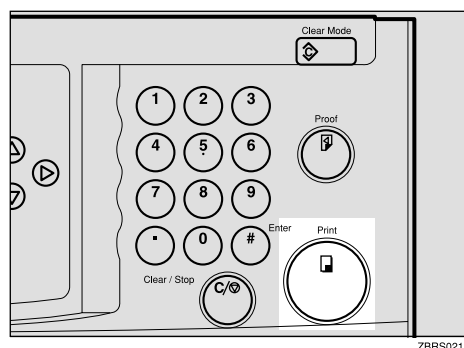

5 Check the image position of the trial or proof print.

Note

- ❑ If the image position is not correct, adjust it using the **[Whole]** or **[Drum2]** key (⇒ P.20 "Adjusting the Position of Printed Images").

6 Make your prints.

2. User Tools

Accessing the User Tools

The user tools allow you to customize various default settings. This section is intended for the machine administrator.

1 Press the **[User Tools]** key.

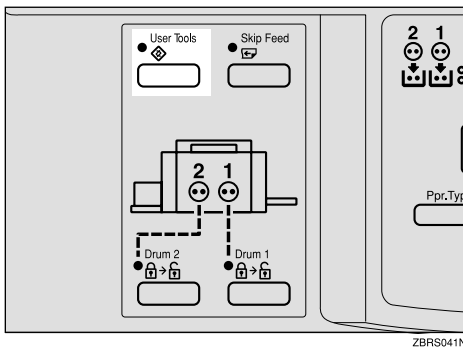

Using the **[Δ]**, or **[▽]** key

1 Search for the desired user tool number with the **[Δ]**, **[▽]**, key.

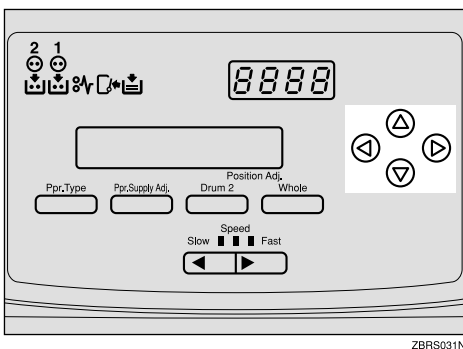

Using the number keys

1 Enter the desired user tool number with the Number keys.

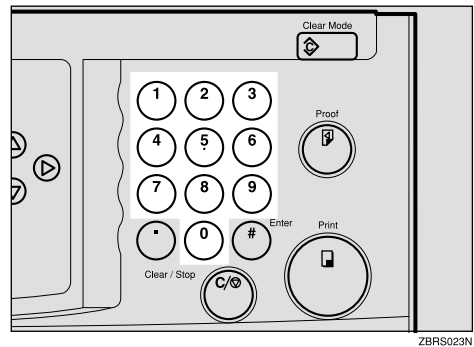

2 Change the settings by following the instructions on the panel display. Then press the **[#]** key.

3 Press the **[User Tools]** key to return to the standby display.

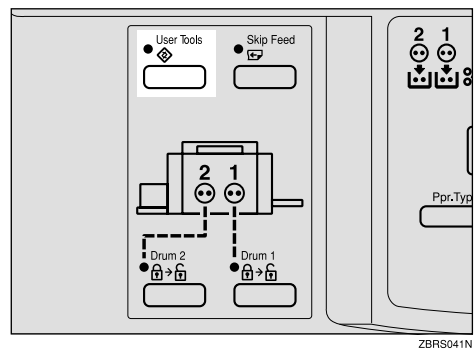

Note

- The settings are not canceled even if the main switch is turned off or the **[Clear Modes]** key is pressed.





User Tools







Reference

For how to access the user tools, ⇒ P.25 “Accessing the User Tools”.

2

1. System

No.	Mode	Description
1	Auto Reset Time	<p>The machine returns to its initial condition automatically after your job is finished. The automatic reset time can be set from 1 to 5 minutes or off (0 minute).</p> <p> Note</p> <p><input type="checkbox"/> Default: <i>Off</i></p>
2	Resettable Count	The counter shows the number of prints you made.
3	Clr Resettable Count	<p>Choose whether the total number of prints is reset.</p> <p> Note</p> <p><input type="checkbox"/> Default: <i>Not clear</i></p>
4	Max Print	<p>The maximum print quantity can be set between 1 and 9999.</p> <p> Note</p> <p><input type="checkbox"/> Default: <i>9999</i></p>
5	Total Counter	Use to display the total number of prints.
6	Buzzer Off	<p>Turns the beeper on or off.</p> <p> Note</p> <p><input type="checkbox"/> Default: <i>STD.</i> (standard)</p> <p><input type="checkbox"/> Available settings:</p> <ul style="list-style-type: none"> • 0: KEY OFF (When you press a key, the beeper does not sound. When warning messages appear on the panel display, the beeper sounds.) • 1: ON (The beeper sounds when you press a key or when warning messages appear on the panel display.) • 2: OFF (The beeper does not sound when you press keys or when warning messages appear on the panel display.)
7	Auto Off	<p>If you do not operate the machine for a certain period the machine can enter Quality Standby mode to remove ink from inside the machine, and then turn itself off. This function is called “Auto Off”. The time can be set from 10 to 90 minutes.</p> <p> Note</p> <p><input type="checkbox"/> Default: <i>60 minutes</i></p> <p><input type="checkbox"/> Quality Standby mode does not available when you use Color Drum Type 40S/50S.</p>

No.	Mode	Description
8	Jump Table	<p>You can change the angle of the wing guide depending on the paper type you use.</p> <p> Note</p> <ul style="list-style-type: none"> <input type="checkbox"/> Default: <i>Auto</i> <input type="checkbox"/> Available settings: <ul style="list-style-type: none"> • Up (Select this setting when standard thickness or thin paper misfeeds at the paper exit section occur frequently.) • Down (Select this setting when A4-B5, 8 1/2" × 11" thick paper is not delivered properly to the paper delivery tray.)
9	Drm Stp Mode	<p>You can select the drum which you will be able to pull out immediately after you finish your job without pressing any key.</p> <p> Note</p> <ul style="list-style-type: none"> <input type="checkbox"/> Default: <i>Drum 1</i>
10	Long Sheet Mode	<p>You can select whether you can use paper longer than 432mm,17.0" or not.</p> <p> Note</p> <ul style="list-style-type: none"> <input type="checkbox"/> Default: <i>Not to use</i> <input type="checkbox"/> When you use paper longer than 432mm, 17.0", lower the paper delivery end plate and receive completed prints by hand.
11	Skip Number of Time	<p>Specifies the number of drum rotations in Skip Feed mode when the power is turned on.</p> <p>You can also select whether you can change the number of drum rotations temporarily when you press the [Skip Feed] key. ⇒ P.23 "Skip Feed Printing"</p> <p> Note</p> <ul style="list-style-type: none"> <input type="checkbox"/> Default: <ul style="list-style-type: none"> • Number of Skip Feed: 2
12	Skip Display On Mode	<p>When you press [Skip Feed] key, you can select whether optional print counts display shows up or not.</p> <p> Note</p> <ul style="list-style-type: none"> <input type="checkbox"/> Default: <i>Off</i>
13	Total Counter Down	<p>The copy counter can be set to show the number of copies made (Count Up), or the number of copies remaining to be made (Count Down).</p> <p> Note</p> <ul style="list-style-type: none"> <input type="checkbox"/> Default: <i>Yes (Count Down)</i>
14	Print Position	<p>You can register the settings of print image position.</p>
15	Feed Setup	<p>You can register the settings for frequently use.</p>

3. Troubleshooting

If Your Machine Does Not Operate as You Want

If a malfunction or a misfeed occurs, the following messages will appear on the panel display.

Message	Meaning
RE-ENTER COPY NUMBER	The number of prints exceeds the maximum print quantity. You can change the maximum number of prints that can be made in one operation with the user tools. ⇒ P.26 "User Tools".
DRUM1: SET COMPLETELY	Slide in the drum until it clicks. Make sure that the drum is completely set in position.
SC**TEL***** CALL SERVICE	Turn the main switch off and on. If the message appears again, contact your service representative.
COLD DRUM NOT TO USE 3RD SPEED	Slow down the printing speed, and then press print key.
DRUM1 UNSITABLE DRUM TYPE	Insert the same kinds of drum unit for both Drum1 and Drum2. If the message appears again, contact your service representative.



When a service call message is shown on the panel display panel

Turn the main switch off and back on again. If a service code appears again, contact your service representative.

If You Cannot Make Prints as You Want

3

Problem	Cause	Action
Misfeeds occur frequently.	Improper paper type is selected.	Select proper paper type. ⇒Refer to the master making unit's operating instructions.
Parts of the image are not printed.	The image is too wide.	<ul style="list-style-type: none"> • Set larger size paper. • Return the drum unit to the master making units, and then reduce the print image size.
Print shadow appears.	The background image density is too high.	<ul style="list-style-type: none"> • Switch drum 1 and 2. • Set thick paper.
The print image appears too light.	The print speed is too fast.	Lower the print speed.
Scratches appear on the print image.	Sharp edges in the machine may have scratched your prints.	<ul style="list-style-type: none"> • Increase the print speed. • Set thick paper.
The images of drum 1 and 2 do not mix well together.	If the image density is too high, the background color might appear strong.	<ul style="list-style-type: none"> • Switch drum 1 and 2. • Use the image of drum 1 for background.
2nd printing with another drum is unsatisfactory.	The 1st print image is still wet.	Wait until the 1st image becomes dry.
Roller marks appear when you print onto the reverse side of paper.	1st printed image is still wet and the press roller becomes dirty.	<ul style="list-style-type: none"> • Wait until the 1st printed image becomes dry. • Wipe off the ink on the press roller. ⇒ P.41 "When the Press Roller is Dirty"
An uneven solid image appears.	Large solid image wrinkles the master.	<ul style="list-style-type: none"> • Increase the print speed. • Set thick paper. • Use Drum2 for a large solid image. • Use Quality Standby mode by pressing the [Clear Mode] key for more than 3 seconds. • Return the drum unit to the master making unit, and then remake the master with economy mode or quality start mode. • When you make master, make a few trial prints, and then return the drum unit to this machine. <p>⇒Refer to the master making unit operating instructions.</p>

Loading Paper

The **Load Paper** indicator (🖨️) lights when the paper feed tray runs out of paper.

⚠️ Limitation

- ❑ Load paper when the paper feed tray is empty. Do not add paper when some paper is left in the tray. Doing so may cause problems, such as multiple feeds and mis-feeds.
- ❑ If you use a variety of paper while printing, a print shadow might appear.

🔍 Reference

For available paper sizes, ⇒ P.13 "Print Paper".

- 1** Load the paper in the Paper feed tray.

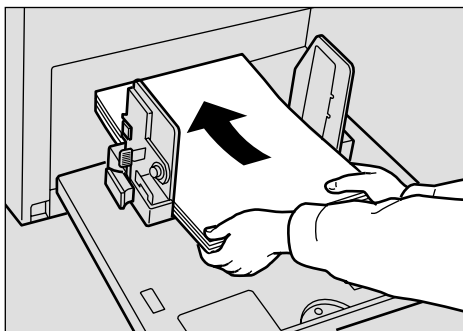

ZBRY050E

📌 Note

- ❑ Correct any paper curl before loading the paper.

- 2** Adjust the paper feed side plate to match the paper size.

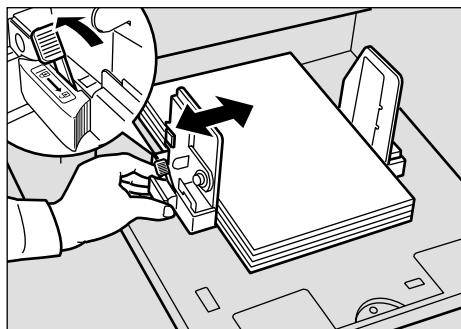

ZBRY060E

When the Add Ink Indicator (🖨️) Lights

The Add Ink indicator (🖨️) lights when it is time to supply ink.

⚠️ CAUTION:

- *If ink comes into contact with your eyes, rinse immediately in running water. In the case of any abnormal symptoms, consult a doctor.*

⚠️ CAUTION:

- *Keep the ink or ink container out of the reach of children.*

⚠️ CAUTION:

- *If ink is ingested, force vomiting by drinking a strong saline solution and consult a doctor immediately.*

⚠️ CAUTION:

- *Our products are engineered to meet high standards of quality and functionality, and we recommend that you only use the expendable supplies available at an authorized dealer.*

📝 Note

- Be sure to supply ink of the same color as the current drum.
- Ink is readily removed from skin by waterless hand cleaners followed by washing with soap and water.
- Be careful not to get any ink on your clothing.
- Store ink under low temperature and humidity conditions.
- Do not store ink where it will be exposed to heat or direct sunlight.
- Store on a flat surface.

1 Open the front door.

2 Pull out the ink holder.

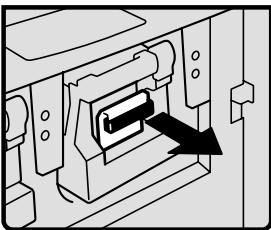

- 3** Remove the used ink cartridge.

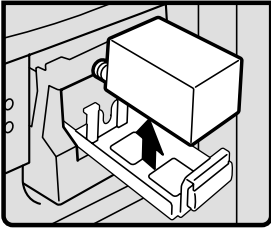

- 4** Remove the cap of the new ink cartridge.

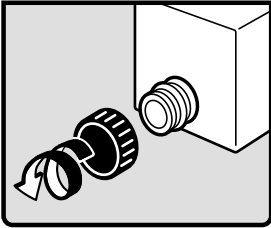

- 5** Insert the new cartridge into the ink holder.

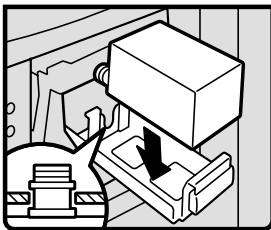

 **Note**

- Always supply ink of the same color.

- 6** Return the ink holder to its original position until it clicks.

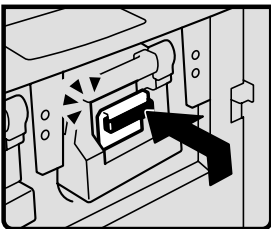

- 7** Close the front door.

The machine will start idling to supply ink to the drum.

Clearing Misfeeds

CAUTION:



• Be careful not to cut yourself on any sharp yellow edges when you reach inside the machine to remove misfed papers.

Note

- ❑ After clearing misfeeds, make sure that all the doors, covers, and units are closed and the indicator is off.
- ❑ To prevent misfeeds, do not leave any torn scraps of paper in the machine.
- ❑ When clearing misfeeds, do not turn off the main switch. If you do, your print settings will be cleared.
- ❑ If misfeeds occur repeatedly, please contact your service representative.

Paper Misfed in the Paper Feed Section

PAPER FEED JAM
REMOVE PAPER

MISFED REGISTRATION
REMOVE PAPER

1 Remove the misfed paper.

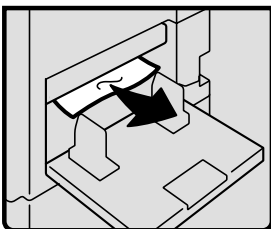

To prevent paper misfeeds:

Check the following before restarting the printing run.

- Did you select an appropriate paper type with the [Ppr.Type] key?

```
PAPER TYPE      1:STD
2:THICK 3:SPL   **
```

- Are the side pads in the correct positions?

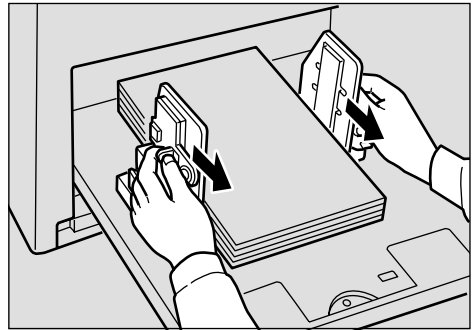

ZBRY070E

To print on thin paper (52.3g/m², 13.9 lb), slide the levers behind the paper feed side plates in the direction of the arrow (see illustration).

- When paper is curled, correct the curl as shown.

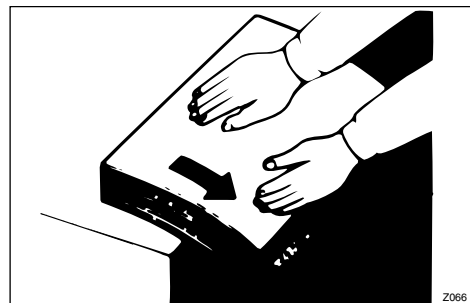

Z068

- When paper edges stick together or paper is not fed in, shuffle the paper as shown.

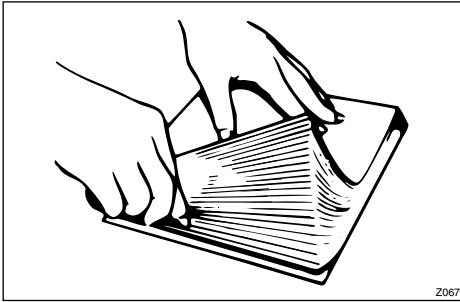

- When printing onto envelopes or thick paper, lower the printing speed. ⇒ P.22 "Changing the Printing Speed".

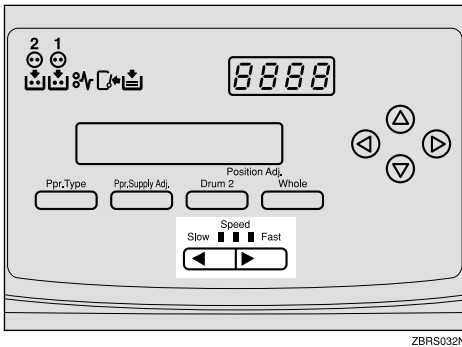

- When a multi-feed occurs or the paper is skewed, make sure that the paper feed side plates are properly adjusted. When you load paper on the paper feed tray, make sure that the paper edge touches the back fence and paper is placed on the proper paper size scale. Only use paper where the leading edge has two right angle corners.

4 Pull out the misfed paper gently

Paper Misfeed in the Paper Feed Section

REGISTRATION JAM
REMOVE PAPER

- 1** Open the front door.
- 2** Lower drum unit lock lever B1.

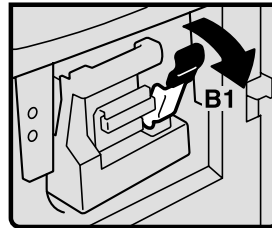

- 3** Take out the drum.

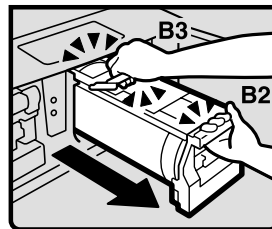
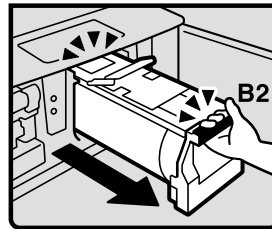

Note

- For how to take out the drum unit, ⇒ P.9 "Changing the Drum Unit".

from the inside.

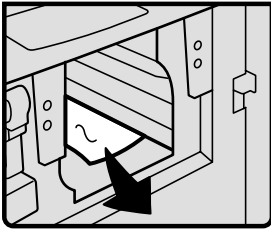

5 If you cannot remove the misfed paper from the inside, remove from the Paper feed tray.

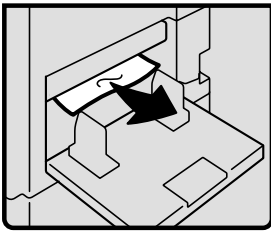

6 Set the drum unit and close the front door.

To prevent paper misfeeds:

⇒ P.34 "Paper Misfeed in the Paper Feed Section".

Paper Wrapped around the Drum

When paper is wrapped around the drum

```
DRUM1:PAPERFED SKEW  
REMOVE PAPER
```

- 1** Open the front cover.
- 2** Lower drum unit lock lever B1.

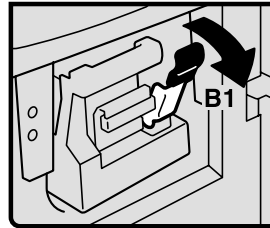

3 Take out the drum.

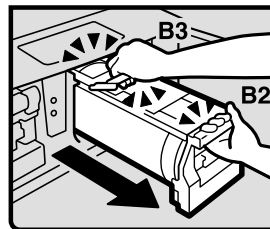
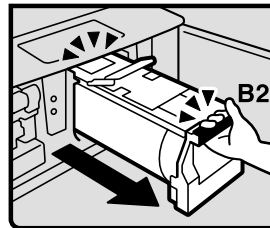

Note

- For how to take out the drum unit, ⇒ P.9 "Changing the Drum Unit".

- 4** Remove the misfed paper from the drum.

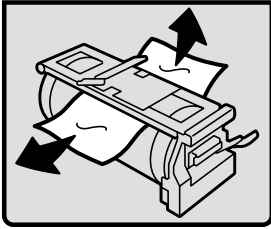

- 5** If you cannot find misfed paper in step 4, remove misfed paper from the press roller.

- 6** Set the drum unit and close the front door.

When paper is misfed inside the machine

DRUM1:DELIVERY JAM
REMOVE PAPER

- 1** Open the front cover.
2 Lower drum unit lock lever B1.

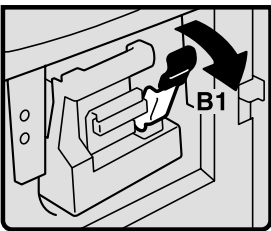

- 3** Take out the drum.

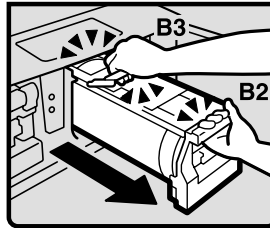
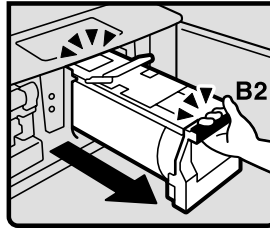

Note

- For how to take out the drum unit, ⇒ P.9 “Changing the Drum Unit”.

- 4** Remove the misfed paper from the inside as shown in the illustration.

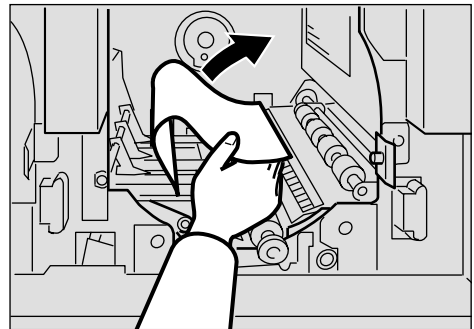

ZBRH100E

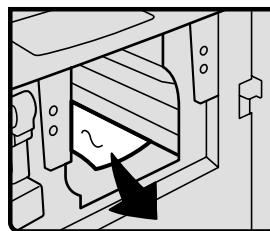

- 5** If you cannot remove the misfed paper, remove paper from the press roller.

- 6 Set the drum unit and close the front door.

To prevent paper misfeeds:

If the paper is curled or the original's leading edge margin is too narrow, the following action is necessary.

- When you use curled paper, correct the curl as shown.

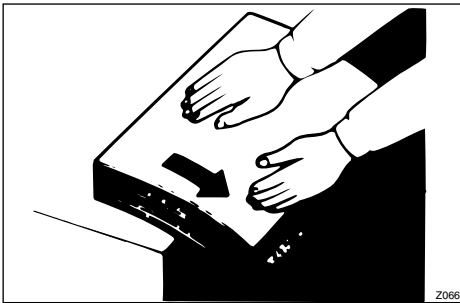

- If you want to know more details about leading edge margin, refer to the master making unit's operating instructions.

Paper Misfeed in the Paper Exit Section

- 1 Slowly but firmly pull out the misfed paper.

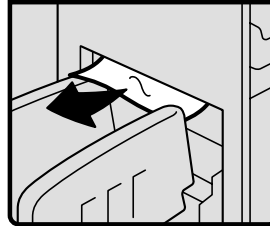

To prevent paper misfeeds:

When a thin paper misfeed in the paper exit section occurs, reduce the printing speed with the [◀][▶] **[Speed]** keys (⇒ P.22 "Changing the Printing Speed"). If you cannot reduce the printing speed, move the end plate toward the paper delivery tray edge.

Poor Printing

Dirty Background

If the background of prints is dirty, the drum unit might be dirty.

⚠ CAUTION:

- If ink comes into contact with your eyes, rinse immediately in running water. In the case of any abnormal symptoms, consult a doctor.

⚠ CAUTION:

- Keep the ink or ink container out of the reach of children.

⚠ CAUTION:

- If ink is ingested, force vomiting by drinking a strong saline solution and consult a doctor immediately.

📌 Note

- ❑ To avoid getting dirty background prints when printing onto paper smaller than the original image, select a suitable reduction ratio or use larger print paper.
- ❑ When printing onto paper that does not absorb ink well, the background of prints might get dirty. In this case, lower the printing speed or use Skip Feed mode to dry the ink on the prints.

1 Open the front cover.

2 Pull out the drum unit.

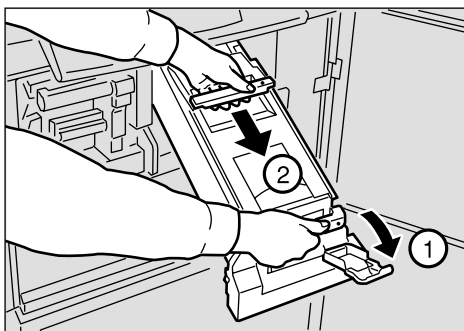

ZBRH061E

📌 Note

- ❑ For how to take out the drum unit, ⇒ P.9 “Changing the Drum Unit”.

- 3** While pressing the drum lock, turn the drum until you can see the trailing edge of the master.

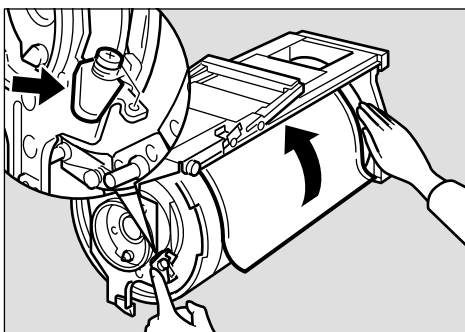

- 4** With a dry soft cloth, remove any ink that has accumulated on the trailing edge of the drum unit.

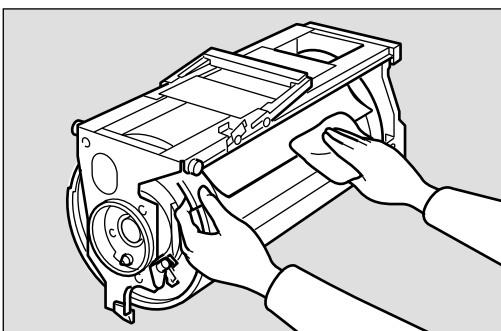

Important

- Do not use benzine, thinner, or other organic liquids—doing so can damage the machine.

- 5** Turn the drum unit and lock it until it click after cleaning it.

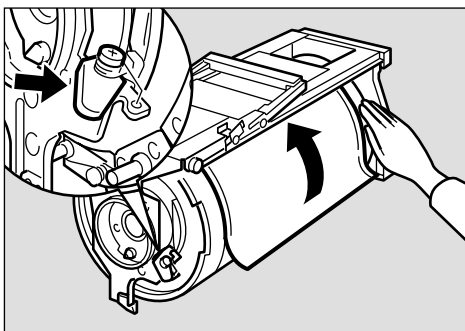

- 6** Insert the drum unit until it locks in position, then lower the drum unit lock lever.

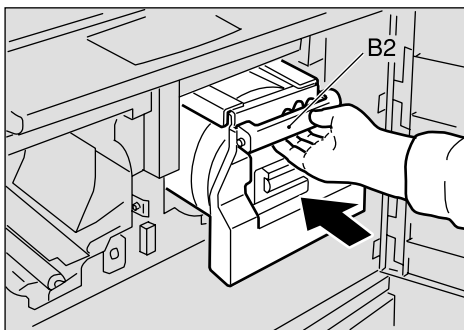

- 7** Close the front door.

When the Press Roller is Dirty

If the background of prints is dirty, the Press Roller might be dirty.

- 1** Make several prints until clear image appears.

 **Note**

- If the print is still dirty, contact your service representative.

Faint Prints

If the machine is not used for a long period of time or you change the color drum unit, the ink on the drum might dry causing print quality to deteriorate. To solve this problem, set back your drum unit to the Master making unit and use Quality Start Mode. ⇒Refer to the Master Making Unit's Operating Instructions.

If the print density is still too light even when using Quality Start mode, remake the master.

Do's and Don'ts

CAUTION:

- *Unplug the power cord from the wall outlet before you move the equipment. While moving the equipment, you should take care that the power cord will not be damaged under the equipment.*

Important

- While printing, do not turn off the main switch.
- While printing, do not unplug the power cord.
- While printing, do not open the door or covers.
- While printing, do not move the machine.
- Open and close the door and covers softly.
- When printing onto paper that contains images on the back, make sure there is a 10mm (0.4") margin at the back leading edge. If there is no margin, the machine might incorrectly detect that paper is wrapped around the drum and stop printing ⇒ Refer to the Master Making Unit's Operating Instructions.
- When you use envelopes or pasted print paper, the leading edge of print might be damaged.
- Make sure to make a few trial prints to check the image position because the image position of the trial print might not correspond with that of the original.
- The leading edge of the prints might become stained if the edge touches the image of prints on the paper delivery tray.
- Print ink on the paper delivery tray might stick to the back side of the next print.
- Press the **[Proof]** key to perform a test print as the image density of the first few prints might be light.
- When the machine is on and the power source is less than 90% of the specified amount, printing quality will decrease. Therefore, make sure the supply from your electrical outlet is at least 90% of the required amount.
- When printing a large solid area on A3, 11" x 17" paper, the sides of the print tend to curl up after the print is fed out to the paper delivery tray. The next sheet that feeds out pushes against the curled sheet and a paper mis-feed occurs. In this case, slow the printing speed down.
- When you make a lot of prints from a small image, ink might ooze out from the edges of the master, especially under high temperature and when printing in two or more colors. In this case, make a new master.
- Large uneven solid image wrinkles the master and you may not print as you want.

Where to Put Your Machine

Environment

Your machine's location should be carefully chosen because environmental conditions greatly affect its performance.

Optimum environmental conditions

⚠ CAUTION:

- *Keep the equipment away from humidity and dust. Otherwise a fire or an electric shock might occur.*
- *Do not place the equipment on an unstable or tilted surface. If it topples over, it could cause injury.*

⚠ CAUTION:

- *If you use the equipment in a confined space, make sure there is a continuous air turnover.*

⚠ CAUTION:

- *After you move the equipment, use the caster fixture to fix it in place. Otherwise the equipment might move or come down to cause a personal injury.*

- Temperature: 10 – 30°C, 50 – 86°F
- Humidity: 20 – 90% RH
- A strong and level floor.
- The machine must be level within 5mm, 0.2" both front to rear and left to right.
- Be sure to locate this machine in a large well ventilated room that has an air turnover of more than 30m³/hr/person.

Environments to avoid

- Locations exposed to direct sunlight or strong light (more than 1500 lux).
- Locations directly exposed to cool air from an air conditioner or heated air from a heater (sudden temperature changes might cause condensation within the machine).
- Places where the machine might be subjected to frequent strong vibration.
- Dusty areas.
- Areas with corrosive gases.

Power Connection

⚠ **WARNING:**

- **Only connect the machine to the power source described on the inside front cover of this manual. Connect the power cord directly into a wall outlet and do not use an extension cord.**
- **Do not damage, break or make any modifications to the power cord. Do not place heavy objects on it. Do not pull it hard nor bend it more than necessary. These actions could cause an electric shock or fire.**

⚠ **CAUTION:**

- *Unplug the power cord from the wall outlet before you move the equipment. While moving the equipment, you should take care that the power cord will not be damaged under the equipment.*

⚠ **CAUTION:**

- *When you disconnect the power plug from the wall outlet, always pull the plug (not the cable).*

Make sure the plug is firmly inserted in the outlet.

Machine Clearance

Place the machine near the power source, providing clearance as shown.

◆ Main frame

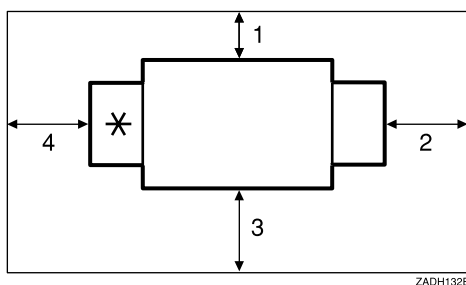

*: Paper delivery tray

1. More than 10cm, 4.0"
2. More than 60cm, 23.7"
3. More than 60cm, 23.7"
4. More than 60cm, 23.7"

Maintaining Your Machine

To maintain high print quality, clean the following parts and units regularly.

❖ Cleaning the machine

Wipe the machine with a soft, damp cloth. Then wipe it with a dry cloth to remove the water.

⚠ Important

- ❑ Do not use chemical cleaner or organic solvent, such as thinner or benzene. If they get into the machine or melt plastic parts, a failure might occur.
- ❑ Do not clean parts other than those specified in this manual. Such parts should be cleaned by your service representative.

4

Cleaning the Main Frame

Cleaning the paper feed roller (Paper feed tray)

- 1** Wipe off the paper dust on the paper feed roller with a damp cloth, then wipe it with a dry cloth.

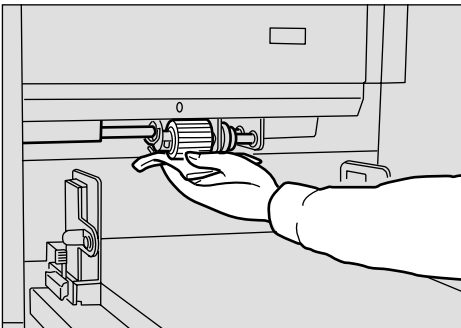

ZBRY130E

📌 Note

- ❑ If you do not clean the paper feed roller, paper misfeeds tend to occur.

5. Specifications

Main Frame

❖ Configuration:

Floor standing (with custom table or cabinet)

❖ Printing Process:

Twin color press roller printing system

❖ Original Size & Printing Area:

Refer to the Master Making Unit's Operating Instructions

❖ Print Paper Size:

Maximum: 297mm × 432mm, 11.6" × 17.0"

Minimum: 70mm × 250mm, 2.8" × 9.8"

❖ Leading Edge Margin:

Refer to the Master Making Unit's Operating Instructions

❖ Print Paper Weight:

- 52.3 – 209.3g/m², 13.9 – 55.6 lb

❖ Print Speed:

90.105.120cpm (3 steps)

❖ Color Printing:

Drum unit replacement system

❖ Image Position:

	Up&Down	Right&Left
Overall Image Adjustment	+10mm, 0.4" or —10mm, 0.4"	+10mm, 0.4" or —10mm, 0.4"
Drum2 Image Adjustment	Moving sums of both adjustment functions (Max 10mm, 0.4")	+5mm, 0.2" or —5mm, 0.2"

❖ Paper Size and Paper Capacity:

1,000 sheets (80g/m², 20 lb)

❖ Paper Delivery Tray Capacity:

1,000 sheets (80g/m², 20 lb)

❖ **Dimensions (W × D × H):**

	Width	Depth	Height
Stored	920 mm, 36.2"	630 mm, 24.8"	555 mm, 21.9"
Set up	1,610 mm, 63.4"	630 mm, 24.8"	555 mm, 21.9"

❖ **Weight:**

- Machine:
Less than 88kg, 194 lb

❖ **Noise Emission ^{*1}:**

Sound Power Level

	Printing Speed	Noise Emission
During printing	90cpm	78dB(A)
	105cpm	80dB(A)
	120cpm	82dB(A)
Stand-by	--	47dB(A)

Sound Pressure Level ^{*2}

	Printing Speed	Noise Emission
During printing	90cpm	65dB(A)
	105cpm	68dB(A)
	120cpm	69dB(A)

^{*1} The above measurement made in accordance with ISO 7779 are actual value.

^{*2} It is measured at the position of the operator.

❖ **Power Consumption:**

- Printing:
0.55kW (Max)

❖ **Optional Equipment:**

- Drum unit: color Drums
A3, 11" × 17"

 **Note**

Specifications are subject to change without notice.

Consumables

Name	Size	Remarks
Ink-Black	1,000ml/pack	Environmental conditions: -5 to 40°C 10 – 95% RH
Ink-Red	1,000ml/pack	
Ink-Blue		
Ink-Green		
Ink-Brown		
Ink-Purple		
Ink-Yellow		
Ink-Navy		
Ink-Maroon		
Ink-Teal		
Ink-Orange		
Ink-Gray		
Ink-Violet		
Ink-Hunter green		
Ink-Burgundy		
Ink-Gold		
Ink-Reflex Blue		

 **Note**

- Specifications are subject to change without notice.

INDEX

[<][>][△][▽], 4

A

accessing the user tools, 25
Add Ink Indicator (▲), 32
adjusting the position of printed images,
20
Auto Off, 26
Auto Reset Time, 26

B

Buzzer Off, 26

C

changing the printing speed, 22
clearing misfeeds, 34
[Clear Modes] key, 4
[Clear/Stop] key, 4
Clr Resettable Count, 26
consumables, 49
Counter, 4

D

dirty background, 39
Drm Stp Mode, 27
[Drum1] key, 4
[Drum2] key, 4
Drum unit, 9
drum unit handle B2, 9
drum unit lock lever B1, 2

E

environment, 44

F

Feed Setup, 27
front door, 1

I

ink, 32, 49
ink holder, 2

J

Jump Table, 27

K

[#] key, 4
keys, 4

L

Loading Paper, 10
loading paper, 31
Load Paper indicator (▲), 31
Long Sheet Mode, 27

M

machine clearance, 45
machine exterior, 1
machine interior, 2
main switch, 2
maintaining your machine, 46
Max Print, 26

N

Number keys, 4

O

operation panel, 1, 4
options, 48

P

paper alignment wings, 2
paper delivery end plate, 2
paper delivery side plates, 2
paper delivery tray, 2
paper feed side plates, 1
Paper feed side plates knob, 1
Paper feed tray, 1
Paper feed tray down key, 1
paper misfeed in the paper exit section, 38
paper misfeed in the paper feed section, 34, 35
paper or master wrapped around the drum, 36
Paper Type, 17
poor printing, 39
【Position Adj/Drum2】 key, 4
【Position Adj/Whole】 key, 4
power connection, 45
【Ppr. Supply Adj】 key, 4
【Ppr.Type】 key, 4
【Print】 key, 4
print paper, 13, 17, 31
Print Position, 27
【Proof】 key, 4

R

Remarks, 43
Resettable Count, 26

S

Safety Information, i
service call, 29
Setting and Changing the Drum Unit, 7
Setting Up the Paper Delivery Table, 11
Skip Display On Mode, 27
【Skip Feed】 key, 4
Skip Feed printing, 23
Skip Number of Time, 27
Special kinds of Paper, 17
specifications, 47
standard paper, 17
standard printing, 15
System, 26

T

thick paper, 17
Total Counter, 26
Total Counter Down, 27
trailing edge guides, 3
Troubleshooting, 29

U

user tools, 25, 26
【User Tools】 key, 4

W

what you can do with this machine, iv
when the image density is too light, 41
where to put your machine, 44
【◀】【▶】 keys (Speed keys), 4

MEMO